



REKORD



The mechanical key machine for flat and cruciform keys

Rekord is the mechanical key cutting machine for flat cylinder and vehicle keys and cruciform keys.

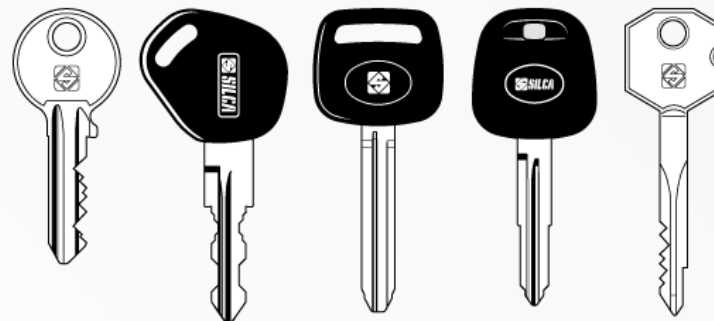

Rekord has been designed and manufactured in conformity with CE mark European standards.

REKORD



The mechanical key machine for flat and cruciform keys

Rekord features:

- smooth and precise carriage movements,
- four-sided rotating clamps with ergonomic handles,
- mechanical tracer point with micrometric adjustment,
- wide tool compartments for making your daily work more practical and comfortable.

REKORD



Smooth and precise carriage movements

- The left hand-side lever ensures **precise shifts without play**, while the self-lubricating DU® bushes guarantee smooth carriage movements.
- **The carriage is released by means of a button** below the ergonomic front lever.
- In the Rekord S version of the machine pushing this button starts the cutter motor.

REKORD



Four-sided clamps

- The sintered four-sided clamps feature **anatomic handles** with a ball bearing system for perfectly fixing the key without damaging the clamp.

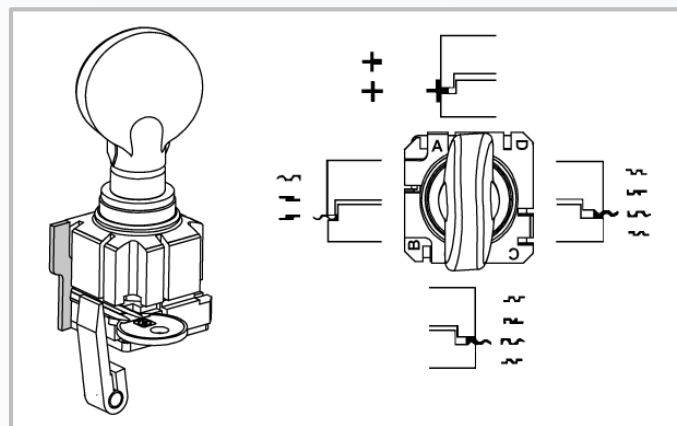

REKORD



Comfortable and efficient work station

- A wide accessories area equipped with an anti-slip mat on the upper part of the machine makes it easy to get the tools used most frequently, such as bars, stops and brushes.
- Below the machine body there is a **practical moulded storage compartment** for stocking other accessories.

REKORD



Easy calibration

- Rekord is equipped with a **mechanical tracer point with micrometric adjustment ring nut** for an easy calibration and quality cutting results.

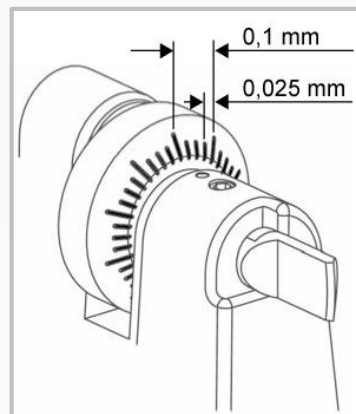

REKORD



Optimized structure for a clean working area

- The sloping structure of the machine ensures an effective disposal of metal chippings, which are collected in the removable swarf tray.

Cut keys finished perfectly

- The de-burring brush is made of tynex and is activated by means of the same power switch which starts the cutter motor.

REKORD



Perfect illumination

- Rekord has a **led light** over the cutter for a clear illumination of the working area.

Safe for the operator

- **The on-off switch features a safety cut-out** for user protection.
- The machine needs to be manually re-started after a power interruption.

REKORD



Technical Data

Power supply	230V-50/60Hz - 120V-60Hz
Cutter motor	single phase and speed
Cutter	HSS (high speed steel)
Cutter speed	1350/1620 rpm (230V-50/60Hz), 1620 rpm (120V-60Hz)
Standard clamp	sintered, rotating 4-sided
Movements	by gear on rectified carriage
Carriage runs	43 mm
Dimensions	Width: 330 mm (including lever: 510 mm), Depth: 430 mm, Height: 270 mm
Weight	19 kg

REKORD



www.silca.biz

© Copyright by Silca S.p.A. 2018 All Rights Reserved

In compliance with current regulations relating to industrial property, we hereby state that the trade-marks or trade names mentioned in this document are the exclusive property of authorized manufacturers of locks and users. Said trade-marks or trade names are nominated only for the purposes of information so that any lock for which our keys are made can be rapidly identified. This document is reserved exclusively for professional key cutters who use Silca products. / All information and illustrations in this document are for guidance only. Silca reserves the right to alter products designs, dimensions or info to improve the products quality. The contents of this document are fully protected by Copyright and may not be copied or reproduced in any form, without written permission from Silca S.p.A. Any controversy shall be settled by the Courts of Justice where the company has its headquarters, with express exclusion of any other court.